

No. 1 1977

issued quarterly

# Technical Review

To Advance Techniques in Acoustical, Electrical and Mechanical Measurement

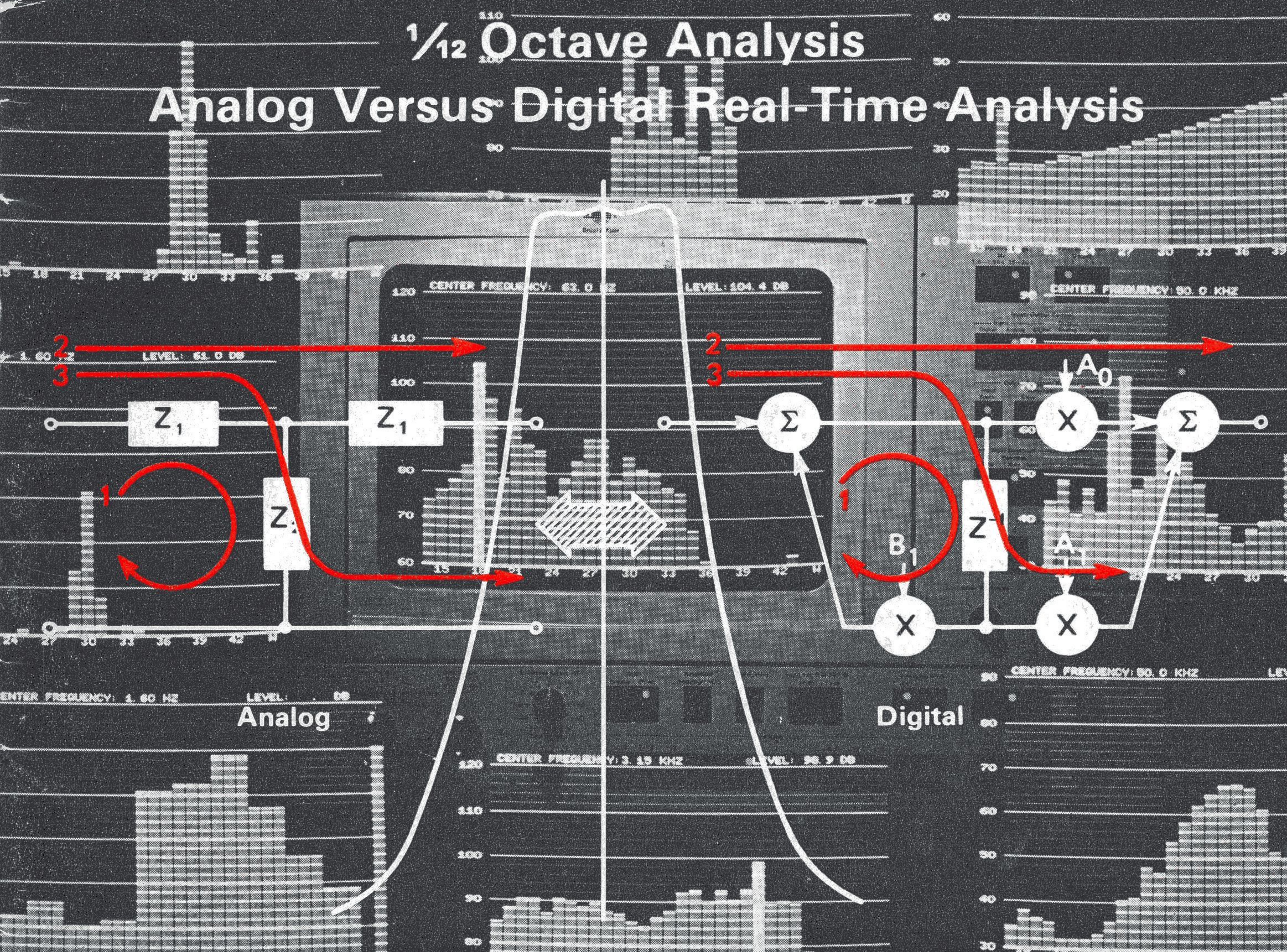

## Brüel & Kjær

**PREVIOUSLY ISSUED NUMBERS OF  
BRÜEL & KJÆR TECHNICAL REVIEW**

- 4-1976 An Easy and Accurate Method of Sound Power Measurements.  
Measurement of Sound Absorption of rooms using a Reference Sound Source.  
Acoustic Noise Measurements (English, Russian), 2. edition  
Strain Measurements
- 3-1976 Registration of Voice Quality.  
Acoustic Response Measurements and Standards for Motion-Picture Theatres.
- 2-1976 Free-Field Response of Sound Level Meters.  
High Frequency Testing of Gramophone Cartridges using an Accelerometer.
- 1-1976 Do We Measure Damaging Noise Correctly?
- 4-1975 On the Measurement of Frequency Response Functions.
- 3-1975 On the Averaging Time of RMS Measurements (continuation).
- 2-1975 On the Averaging Time of RMS Measurements  
Averaging Time of Level Recorder Type 2306 and "Fast" and "Slow" Response of Level Recorders 2305/06/07
- 1-1975 Problems in Telephone Measurements.  
Proposals for the Measurement of Loudness Ratings of Operators' Headsets.  
Comparison of Results obtained by Subjective Measuring Methods.  
Repeatabilities in Electro-Acoustic Measurements on Telephone Capsules.  
Stable Subset Measurements with the 73 D  
Vibration Testing of Telephone Equipment.
- 4-1974 Underwater Impulse Measurements.  
A Comparison of ISO and OSHA Noise Dose Measurements.  
Sound Radiation from Loudspeaker System with the Symmetry of the Platonic Solids.
- 3-1974 Acoustical Investigation of an Impact Drill.  
Measurement of the Dynamic Mass of the Hand-arm System.
- 2-1974 On Signal/Noise Ratio of Tape Recorders.  
On the Operating Performance of the Tape Recorder Type 7003 in a Vibrating Environment.

*(Continued on cover page 3)*

# TECHNICAL REVIEW

No. 1 — 1977

# Contents

<b>Digital Filters in Acoustic Analysis Systems</b> by O. Roth .....	3
<b>An Objective Comparison of Analog and Digital Methods of Real-Time Frequency Analysis</b> by R. Upton .....	18
<b>News from the Factory .....</b>	27

# Digital Filters in Acoustic Analysis Systems

by

*Ole Roth*

## **ABSTRACT**

The digital techniques can provide a 1/3 and 1/1 octave real-time parallel analyzer system with a number of attractive features difficult to achieve by analogue means. By full utilization of the flexibility inherent in digital filter circuitry and the use of time-sharing technique a filter unit is built using commercially available integrated circuits. The flexibility of the filter unit permits other than 1/1 and 1/3 octave analysis. Some are suggested (1/12 octave analyses and critical bandwidth analysis).

## **SOMMAIRE**

Les techniques numériques permettent d'obtenir un système d'analyse parallèle en temps réel en bandes d'octave et de tiers d'octave ayant de nombreuses caractéristiques intéressantes qu'il est impossible d'obtenir par des moyens analogiques. La pleine utilisation de la souplesse propre aux circuits de filtrage numérique et l'emploi de la technique du temps partagé permettent de construire une unité de filtrage utilisant les circuits intégrés disponibles sur le marché. La souplesse de cette unité de filtrage permet d'autres analyses que celles en bandes d'octave et de tiers d'octave. Certaines de ces analyses sont suggérées (par exemple l'analyse en bandes d'un douzième d'octave et l'analyse en bandes critiques).

## **ZUSAMMENFASSUNG**

Die Digitaltechnik ermöglicht ein paralleles Terz- und Oktavezeitanalysensystem, welches eine Anzahl attraktiver Merkmale bietet, die mit der Analogtechnik nicht möglich sind. Die Vielseitigkeit der Digitalfilter wird voll ausgenutzt. Die Filtereinheiten arbeiten im Zeitmultiplexverfahren und sind aus im Handel erhältlichen integrierten Schaltkreisen aufgebaut. Die Vielseitigkeit der digitalen Filter erlaubt auch andere als Terz- und Oktavanalysen. Einige werden erwähnt (z.B. 1/12 Oktavanalyse und kritische Bandbreiten Analyse).

## **Introduction**

In spite of the ever increasing number of publications on digital filters

appearing in literature, very few commercially available instruments use the digital filter techniques. This paper will discuss digital filters, at first in general terms, thereafter in relation to 1/1 or 1/3 octave filter set for a parallel analyzer for the acoustic field. Some possible future measurement capabilities will be described.

A digital system for 1/3 octave real-time analyses implementing digital filtering offers a number of attractive features. For instance, a digital filter has a better controlled filter shape and a greater freedom from drift than its analogue equivalent. Further, the system is not burdened with the same physical limitations for increasing accuracy or dynamic range, a problem arising for RMS measurements. It requires no special trimming to maintain its properties as components age. It is inherently more flexible. However, probably the most important advantages are that digital filtering techniques greatly simplify the use of a digital detector and a digital averager, which gives a flexibility impossible to achieve by analogue means, in that it can offer both linear and exponential averaging.

### **General**

A digital filter is one in which signals are represented as sequences of numbers. These signals are known as digital signals. The digital filter operates on these digital signals in a similar way as the conventional filters perform on analogue signals. The signals to be processed by a digital filter may originate in an analogue-to-digital converter in which case they represent some real-time analogue signal. Theoretically a digital signal can represent an analogue signal with full fidelity and without loss of information, though very careful design is necessary to keep the distortion within limits — a factor not to be forgotten when considering digital systems for processing analogue signals.

### **Filter Characteristic**

A digital filter considered as a black box must in principle function as an equivalent analogue filter. The latter operating on the analogue signal the former on a digital representation of the signal.

Analogue systems or continuous-time systems are described by a differential equation and by using the Laplace transformation the transfer function can be found. It can be written in the form:

$$H(s) = \frac{(s + r_1)(s + r_2)}{(s + p_1)(s + p_2)} \quad (1)$$

where  $s$  is the Laplace Operator,  $r_{1,2}$  are the zeroes and  $p_{1,2}$  are the poles. Similarly, the digital systems or discrete time systems are described by difference equations and the  $z$ -transform plays in these a role analogous to that of the laplace transform in continuous-time systems.

The  $z$ -transform  $X(z)$  of a sequence  $x(nT)$  is defined as:

$$X(z) = \sum_{n=0}^{\infty} x(nT) z^{-n} \quad (2)$$

where  $z$  is a complex variable.

$z^{-1}$  ( $= e^{-sT}$ ) corresponds to a time delay, and is often termed the unit delay operator, since a delay of the sequence by one sample is equivalent to multiplication of the  $z$  transform by  $z^{-1}$ .

Application of the  $z$  transform to the difference equation yields the transfer function of the digital system, which can be written as:

$$H(z) = \frac{A_0 + A_1 z^{-1} + A_2 z^{-2}}{1 - B_1 z^{-1} - B_2 z^{-2}} \quad (3)$$

The similarity between the transfer functions for the two types of systems is evident.

A block diagram of a two pole digital filter is shown in Fig. 1. The filter consists of two time delays ( $z^{-1}$ ) and 5 multipliers ( $\times$ ). The multiplier coefficients  $A_0$ ,  $A_1$ ,  $A_2$ ,  $B_1$  and  $B_2$  define the filter response.  $B_1$  and  $B_2$  are the poles and  $A_0$ ,  $A_1$  and  $A_2$  the zeroes of the filter.

Note, the arithmetic operations defined by the transfer function are directly realized in the block diagram and the coefficients of the numerator and the denominator are represented explicitly. This provides a very flexible filter design with its properties, i.e. its shape, its relative bandwidth, and whether it is highpass, lowpass, bandpass or bandstop defined by the chosen multiplier coefficients.

The delay  $z^{-1}$  corresponds to one sampling interval, and determines the frequency range in which the filter operates. Hence, by altering the sampling interval, it is possible to alter the frequency range in which the filter operates. For instance, doubling the sampling interval (i.e.

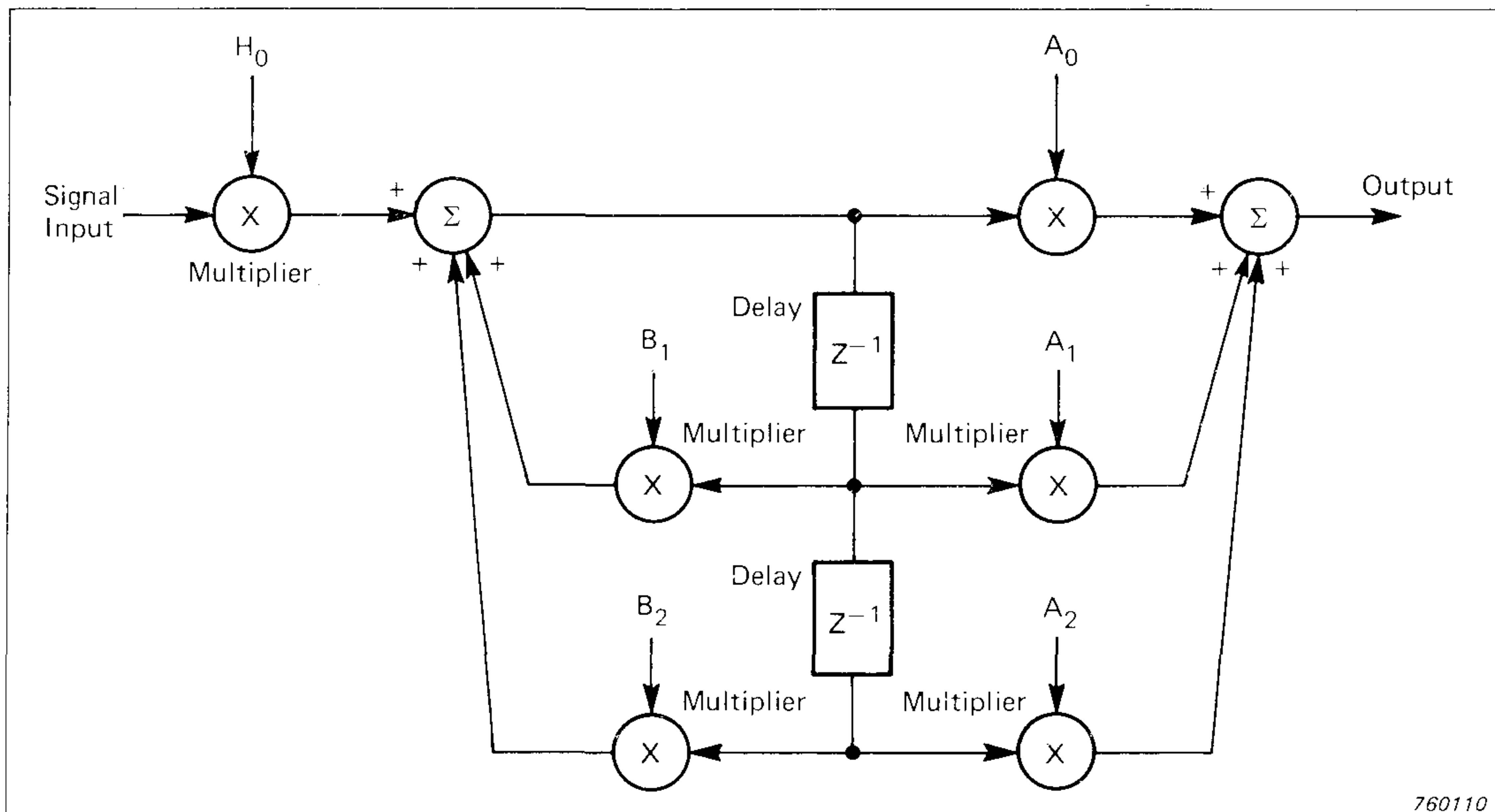

*Fig.1. Two pole digital filter*

halving the sampling frequency), will mean that the filter operates with the same relative bandwidth, but in a frequency range one octave lower.

The digital circuit shown in Fig.1 is very general and has an inherent flexibility which could hardly be obtained by using analogue techniques.

### **Implementation**

We shall in the following consider some general issues involved in the design of a 42 channel 1/3 octave filter set with centre frequencies from 1,6 Hz to 20 kHz, used in a real-time parallel analyzer.

The two pole filter section discussed so far is inadequate for this application. An extension to more poles would be easy by adding more multipliers. However, it is found that better performance with respect to filter noise is obtained by combining a number of simple two pole sections either in series or parallel to form a multipole filter.

Hardware may be saved by time sharing. For instance the signal may pass through the same filter more than once to produce multipole filtering. Or "parallel" filtering may be performed by changing the multiplier coefficients  $A_0$ ,  $A_1$ ,  $A_2$ ,  $B_1$  and  $B_2$ ), and thereby the transfer function of the filter between passes. Looking first at the operation within the highest octave of the frequency range, the sampled value in digital



form is fed to the 20 kHz filters and processed, after which the address to the ROM (Read Only Memory), where the filter coefficients are placed, is changed so that the same sampled value is read in for the 16 kHz filter, and similarly for the 12,5 kHz filter, i.e. three different calculations are performed on each sample to produce three new samples representing the 1/3 octave filtered levels within the octave.

Operations within the lower octaves is obtained by reducing the sampling frequency. If every other sample of the original series of samples is taken (corresponding to halving of sampling frequency), one would automatically obtain the analysis in the frequency range an octave lower. Naturally suitable lowpass filtering must be carried out to avoid aliasing. This procedure is continued, whereby only one central processor unit is required, which can be time shared between all the desired filters. The capacity of the processor must be such that it can manage twice as many computations as that required for the uppermost octave filter.

Thus if the time required for the uppermost octave is 1, the time required for the next lower octave would be 1/2 and for the next would be 1/4 and so on, such that the total time would never exceed 2. It is therefore possible to extend the frequency as low as one wishes without significant increase in cost, which is basically determined by the highest real-time frequency to be operated with. In acoustics the frequency range of interest is relatively low, and it is possible to build an inexpensive processor from standard medium speed digital circuits.

### **Possibilities**

Although the filter bank considered was optimized to carry out 1/3 and 1/1 octave real-time measurements, the capacity of the system permits 1/6, 1/12 and 1/24 octave analysis to be performed. In the following it will be shown how 1/12 octave analysis can be achieved. However, the analysis cannot be obtained in real-time, but that is generally not so important as the narrow bandwidth of the filter requires a relatively long measurement time.

Since the system has a computing capacity for 1/3 octave real-time analysis up to 20 kHz it is possible to compute for 3 different filters in each octave. As mentioned above it is possible to change from one filter to another simply by changing the filter coefficients. If one therefore has a ROM large enough, it is possible to extract a new set of filters by changing the address to the ROM. This is carried out in the following manner.

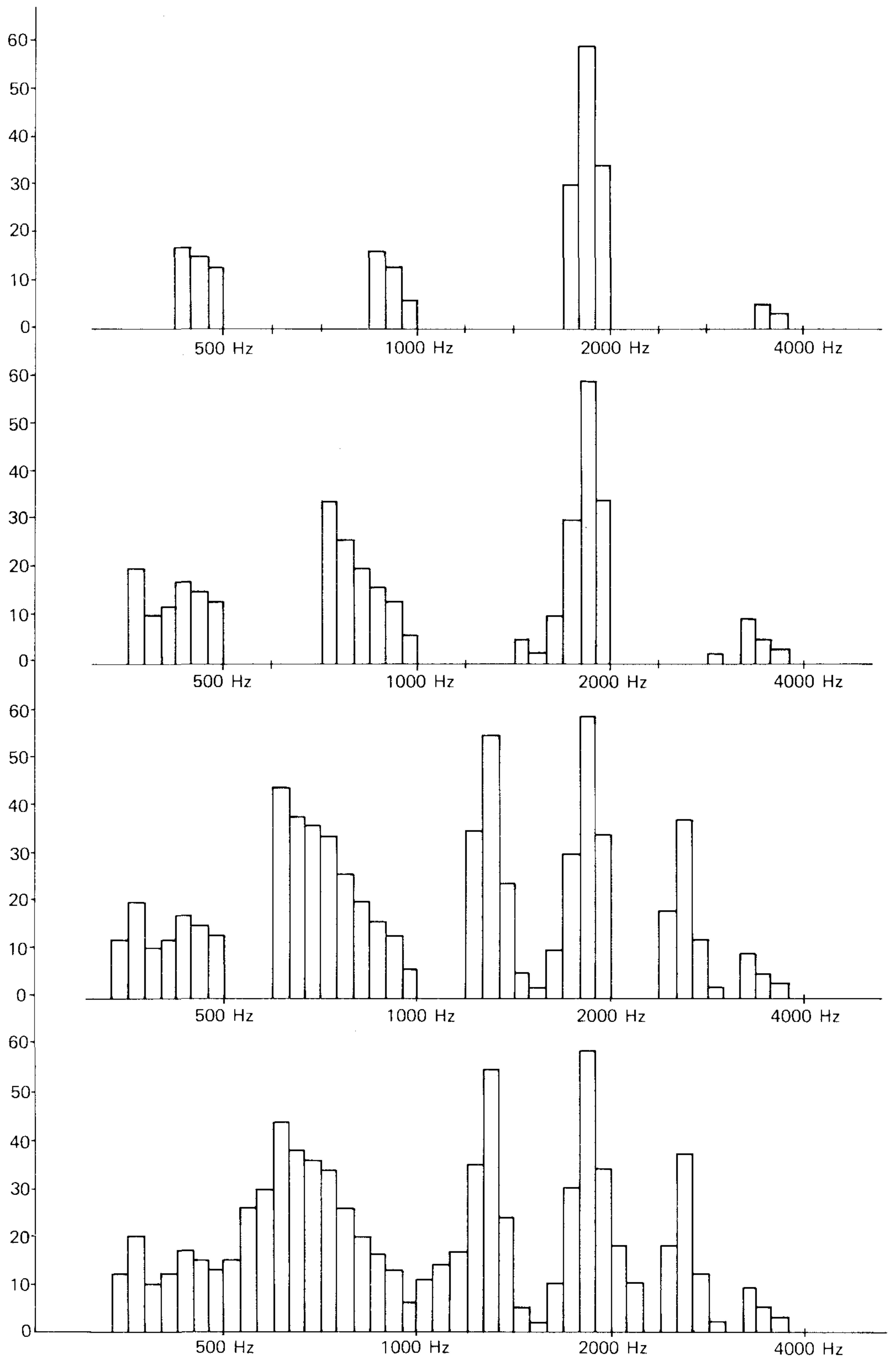

770156

Fig.2. 1/12 octave analysis

The first three 1/12 octave filters in each octave is computed, the analysis of which is ready for display. The address to the ROM is now changed; the next three 1/12 octave filters are activated, the results of which are now displayed, and the procedure repeated for the rest of the filters. The results of the complete analysis, however, do not appear in a convenient form to be handled. A medium is necessary to store the individual results, sort them in the correct sequence and display them. A computer or a desk calculator with a graphic display would be suitable.

One could display the complete 1/12 octave analysis from 1,6 Hz to 20 kHz as shown in Fig.2. Altogether these would be 168 channels, i.e. 12 1/12 octaves in 14 octave bands. Obviously only a part of the spectrum may also be displayed if so desired.

In the appendix listings of programmes required to carry out 1/12 octave analysis with the aid of Hewlett Packard 9825A calculator and Tektronix 4051 Graphic Computing system are given.

Up till now the constant percentage bandwidth analysis (constant Q) has been discussed for which the processor is optimized. However, with a suitable control unit it could carry out other types of analysis.

Consider a signal with a spectrum as shown in Fig.3. We want to measure the magnitude of the components:  $f_1$ ,  $f_1 + k\Delta f$ , and  $f_1 - k\Delta f$  i.e. sidebands);  $f_1$ ,  $k$  and  $\Delta f$  being known. In this case 1/3 octave analysis is first carried out, as the primary measurement, after which the address to the ROM is changed such that the three constant bandwidth filters with centre frequencies  $f_1 - k\Delta f$ ,  $f_1$  and  $f_1 + k\Delta f$ , are coupled in.

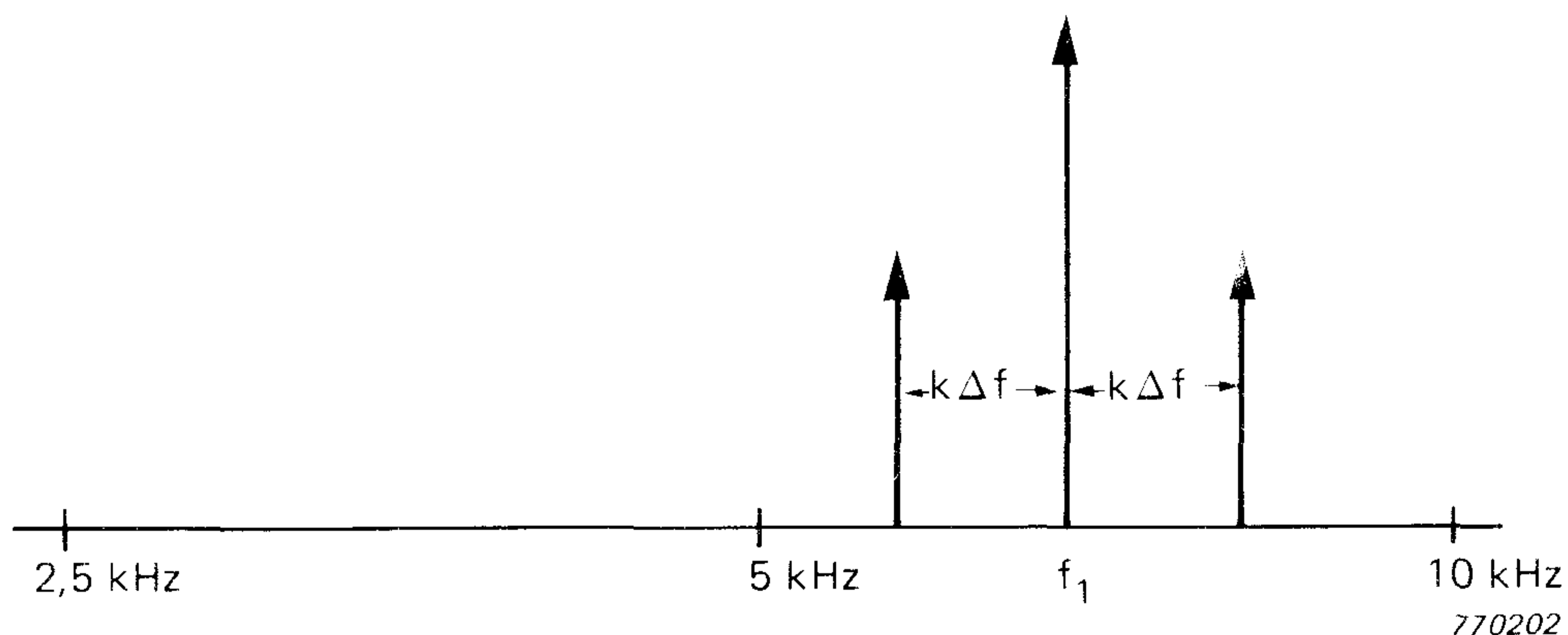

Fig.3. Sidebands around frequency  $f_1$

It must be assumed that the three filters are within an octave. The complete frequency range will however, be analyzed with 3 filters in each octave, but the control unit can then be made to choose the three filters of interest and neglect the others.

It is sometimes desired to measure with critical bandwidths (after Zwicker's method). This can be achieved by carrying out the analysis in two steps. In the first step the frequency range 50 Hz to 1000 Hz is analyzed, while the range 1170 Hz — 13,5 kHz is analyzed in the second. If the analysis is desired in real-time the frequency range must be limited from 50 Hz to 8,5 kHz.

Another type of analysis that can be carried out is one in which a broader bandwidth is desired instead of a smaller bandwidth, e.g. 1/3 octave analysis in the frequency range 200 Hz to 20 kHz and 1/1 octave analysis in the range 2 Hz — 200 Hz. This could be carried out in real-time.

## APPENDIX

### **1/12 Octave Analysis Using Tektronix 4051 Graphic Computing System or Hewlett Packard 9825A Calculator**

The Digital Frequency Analyzer Type 2131 holds coefficients in its ROMS to generate a 1/12 octave analysis. Access to these coefficients is made over the IEC interface with the aid of either a Tektronix 4051 Graphic Computing System (minimum memory 16K) or Hewlett Packard 4825A Calculator (with HP/IB interface 98034A, ROM 98210A and ROM 98213A).

The 1/12 octave analysis for continuous signals is made in 4 passes, with one 1/12 octave being generated in each 1/3 octave with each pass. All the functions on the 2131 necessary for 1/12 octave analysis are controlled by the programs. However, the level adjustments must be chosen manually as well as the averaging times which should be correspondingly longer on account of the narrower bandwidths.

Following are the instructions and listings for the programs for Hewlett Packard 9825A Calculator and Tektronix 4051 Graphic Computing system.

#### *a) Program Listing for Hewlett Packard 9825A Calculator*

STEP	DISPLAY	INSTRUCTIONS
1		Connect HP-9825 and B & K 2131 through HP/IB interface
2		Turn power "ON"
3		Insert cartridge in calculator
4		Press 'edl N'; 'EXEC'; N is program file #
5		Press 'RUN'
	1/12 oct program	the program is now running and the 2131 operating in 1/3 oct. mode

STEP	DISPLAY	INSTRUCTIONS
6	Press 'CONT' to start analysis	the program is now waiting (in 1/3 oct. mode) and averaging times and input att. can be set. When 'CONT' is pressed the 2131 changes to 1/12 oct. mode
7	F0: 6,88 Hz level xx,x dB	When the 4 steps involved in 1/12 oct. analysis are concluded, the frequency range from 1,45 Hz to 6,88 Hz is displayed on 2131 and the centre frequency of the position of the channel selector is put on the calculator display together with the corresponding level. The channel selector is controlled by special function buttons $f_0$ (down in freq.) and $f_1$ (up in freq.)
8	F0 xxx,x Hz level yy,y dB	When the channel selector moves out of the screen the frequency window automatically rolls 6/12 oct. up or down corresponding to the channel selector movement
9		If further analysis is wanted press special function button ' $f_2$ ' and on the display appears:
10	Hand copy/exit or analysis?	
11		If 'CONT' is pressed the calculator returns to step 6. When step 7 is reached for the second time the frequency range displayed on the screen will be the same as the last obtained in the preceding step 8. If 'Y' is pressed the calculator continues with step 12
12	Lower and upper frequency range	The calculator is now ready to make a hard copy of frequency versus level and if a lower and an upper frequency is entered: ex. 73 'CONT' 180 'CONT' this will be the result The calculator then returns to step 10 (If $f_{lower} > f_{upper}$ the calculator repeats step 12)
13		If 'CONT' is pressed instead of a lower and an upper frequency, the program stops  Note: if $f_0$ or $f_1$ is pressed continuously an error message can appear on the display. This, however, is of no consequence and should be disregarded

```

0: "Datum of copy : 3/11/1977":
1: cfg ;dsp "1/12 oct. program"
2: prt "1/12 Octave";prt "          analysis";soc
3: dim A$(1),B$(2),C$[1183],D$[1203+16],G$[6]
4: "@ "→B$;16→P;trk 0;ldk 12
5: buf "in",D$,3
6: "ana":cli 7;wait 500
7: wrt 717,"E=F?I?J>K>@0 D="
8: ent "Press 'CONT' to start analysis",A$
9: wrt 717,"O";red 717,A$
10: if num(A$)<51;dsp "68% Confidence Levels not usable";jmp -1
11: 2↑(num(A$)-56)→A;dsp " "
12: for I=2 to 5
13: char(I+50)→B$[2];0→B
14: wrt 717,B$
15: wrt 717,"M?";wait 50;wrt 717,"M>";wait 10;wrt 717,"M="
16: if (B+1→B)<17;wait 250A;jmp 0
17: wrt 717,"E?"
18: tfr 716,"in",302
19: jmp rds("in")#-1
20: wrt 717,"E="
21: next I
22: D$[1,7]→C$[1,7]
23: for I=2 to 43 by 3
24: for J=3 to 0 by -1
25: D$[302J+7I-6,302J+7I+14]→C$[28I-21J+15,28I-21J+35]
26: next J
27: next I
28: P-20→M;P+9→V;P→C
29: "rr":1kd
30: V+6→V;M+6→M
31: if V>169;169→V;140→M
32: if M<2;2→M;31→V
33: if C<M;C+24→C
34: gsb "wrt"
35: gsb "Freq"
36: lke
37: stp
38: "stp":stp
39: "lr":1kd
40: V-6→V;M-6→M
41: if M<2;2→M;31→V
42: if C>V;C-24→C
43: gsb "wrt"
44: gsb "Freq"
45: lke
46: stp
47: "rs":1kd
48: if (C+1→C)>V;C-1→C;gto "rr"
49: wrt 717,"E=D>E?"
50: gsb "Freq"
51: lke
52: stp
53: "ls":1kd
54: if (C-1→C)<M;C+1→C;gto "lr"
55: wrt 717,"E=D?E?"
56: gsb "Freq"
57: lke

```

```

58: stp
59: "lock":
60: C→P
61: ent "Hard copy/exit(Y) or analysis ?",A$
62: if flgl3;buf "in";gto "ana"
63: ent "Lower and upper frequency",L,U
64: if flgl3;gto "end"
65: if L<1.45 or L>U;dsp "Illegal interval !";wait 1000;jmp -2
66: if U>21753 or U<L;dsp "Illegal interval !";wait 1000;jmp -3
67: int(40/log(10)*log(U/15400)+163+.5)→U
68: int(40/log(10)*log(L/15400)+163+.5)→L
69: prt "Freq-          Le-";prt "ency(Hz) vel(dB) "
70: prt "-----";spc
71: cfg
72: for C=L to U
73: gsb "Freq"
74: if flgl1;cfg 1;fmt 1,2x,f7.2,lx,c6
75: if flg2;cfg 2;fmt 1,2x,f6.1,2x,c6
76: if flg3;cfg 3;fmt 1,f6.0,4x,c6
77: wrt 16.1,F,G$
78: next C
79: spc 3
80: gto "lock"
81: "Freq":
82: fxd 1;str(val(C$[7C-6,7C]))→G$
83: 10↑((C-163)/40)15400→F
84: if C<76;sfg 1;fxd 2;jmp 3
85: if C<116;sfg 2;fxd 1;jmp 2
86: fxd 0;sfg 3
87: dsp "F0:",F," Hz  Level",G$," dB"
88: ret
89: "wrt":
90: wrt 717,"E=F>"
91: wrt 716,C$[1,7],C$[7M-6,7V]
92: wrt 717,"D="
93: for I=M to C-1
94: wrt 717,"D>"
95: next I
96: wrt 717,"F?J?E?"
97: ret
98: "end":trk 1;ldk 0;end
*11862

```

f0: \*cont"ls"

f1: \*cont"rs"

f2: \*cont"lock"



*b) Program Listing for Tektronix 4051 Graphic Computing System*

```
1 PAGE
2 PRINT "1/12 OCTAVE ANALYSIS:"
100 INIT
110 SET KEY
120 DIM A$(303),B$(7),C(43,4), D(169),S(43)
130 PRINT "WAIT FOR MAG. TAPE. (RETURN)";
140 INPUT Q$
150 WBYTE @49:64,50
160 WBYTE @49:77,63
170 WBYTE @49:73,63
180 WBYTE @49:77,61
190 WINDOW 0,42,—5,60
200 VIEWPORT 30,130,5,90
210 MOVE 0,60
220 DRAW 0,0
230 MOVE 0,0
240 FOR I=1 TO 42
250 RDRAW 1,0
260 RDRAW 0,—0.5
270 RDRAW 0,0.5
280 NEXT I
290 FOR L=0 TO 13
300 MOVE 3*L+0.2,—3
310 IF L>2 THEN 330
320 RMOVE 0.25,0
330 PRINT 3*L+3
340 NEXT L
350 MOVE 0,0
360 TO=6
370 GOSUB 1400
380 FOR J=1 TO 4
390 Q=3—0.75*J
400 WBYTE @49:79
410 WBYTE @95,63:
420 WBYTE @81:
430 RBYTE TO
440 TO=2↑(TO—56)—12
450 IF TO<0 THEN 465
460 GOSUB 1400
465 HOME
466 PRINT
470 PRINT "WAIT FOR MAG. TAPE. (RETURN)";
480 INPUT Q$
490 PRINT @17:"E?"
500 PRINT @37,0:4,4,13
510 INPUT %16:A$
520 H=50+J
530 PRINT @17:"M?"
540 WBYTE @49:64,H
550 TO=0.2
560 GOSUB 1400
570 PRINT @17:"M="
580 FOR I=0 TO 42
590 A$=REP(" ",I*6+4,1)
600 NEXT I
```

```

610 FOR I=0 TO 42
620 B$=SEG(A$,I*6+1,5)
630 C(I+1,J)=VAL(B$)
640 NEXT I
650 IF J<>1 THEN 720
660 FOR M=0 TO 6
670 MOVE 0,10*M
680 DRAW 42,10*M
690 MOVE -3,10*M-1
700 PRINT 10*M+C(1,1)
710 NEXT M
720 MOVE Q,0
730 FOR N=0 TO 41 STEP 3
740 FOR E=0 TO 2
750 V=C(N+E+2,J)-C(1,1)
760 DRAW N+E/4+Q,V
770 DRAW N+E/4+Q+0.25,V
780 DRAW N+E/4+Q+0.25,0
790 D(12*(N/3+1)+E-3*J+2)=C(N+E+2,J)
800 NEXT E
810 RDRAW 2.25,0
820 NEXT N
830 NEXT J
840 S(1)=C(1,1)
850 WBYTE@49:64,48
860 Q2=0
870 MOVE 0,1.5
880 PRINT USING 890:"MIDDLE OF INTERVAL:"
890 IMAGE ///,20A,S
900 IF Q2=0 THEN 940
910 FOR I=1 TO Q2
920 PRINT " \ ";
930 NEXT I
940 Q2=Q2+1
950 PRINT@32,26:1
960 INPUT N
970 IF N>8 THEN 990
980 N=8
990 IF N<38 THEN 1010
1000 N=38
1010 N=4*N-30+1
1020 FOR I=N TO N+41
1030 S(I+2-N)=D(I)
1040 NEXT I
1050 A$=CHR(4)
1060 D$=CHR(13)
1070 E$=CHR(10)
1080 D$=REP(E$,2,0)
1090 FOR I=1 TO 43
1100 X=INT(10*S(I)+0.5)/10.
1110 B$=STR(X)
1120 L=LEN(B$)
1130 L=L-1
1140 B$=SEG(B$,2,L)
1150 P=7*(I-1)
1160 IF L=1 THEN 1210
1170 C$=SEG(B$,L-1,1)
1180 IF C$="." THEN 1270
1190 J=4-L

```

```
1200 IF L=>3 THEN 1240
1210 FOR J=1 TO 3--L
1220 A$=REP("0",P+J,0)
1230 NEXT J
1240 A$=REP(B$,P+J,0)
1250 A$=REP(".0",P+4,0)
1260 GO TO 1330
1270 J=6--L
1280 IF L=>5 THEN 1320
1290 FOR J=1 TO 5--L
1300 A$=REP("0";P+J,0)
1310 NEXT J
1320 A$=REP(B$,P+J,0)
1330 A$=REP(D$,P+6,0)
1340 NEXT I
1350 A$=SEG(A$,1,301)
1360 WBYTE @49:70,62
1370 PRINT %16:A$
1380 WBYTE @49:70,63
1390 GO TO 870
1400 TO=220*TO
1410 FOR T1=1 TO TO
1420 NEXT T1
1430 RETURN
1440 END
```

# An Objective Comparison of Analog and Digital Methods of Real-time Frequency Analysis<sup>\*</sup>

by

*Roger Upton B.Sc.*

## **ABSTRACT**

In recent years, the tendency has been for real-time frequency analysis methods to become more and more predominantly digital in nature. Digital methods have been in use for some time for the calculation of cross properties and the like, in two channel and multichannel systems, quite simply because they were the only practical methods to use. Now, however, with the continuing advancements being made particularly in semiconductor technology, the application of digital techniques to problems once solved by analog methods is spreading. Hence, the increasing use of Fast Fourier Transform methods is found in single channel real-time narrow band measurements, once the sole domain of the Time Compression Analyzer. Likewise, Digital Filtering is replacing the Analog Filter bank which was so long used as the basis for real-time analyzers operating with constant percentage bandwidth.

## **SOMMAIRE**

Au cours des dernières années, les méthodes d'analyse en fréquence en temps réel ont eu tendance à devenir de plus en plus largement de nature numérique. Les méthodes numériques ont été utilisées depuis un certain temps pour le calcul des propriétés croisées dans les systèmes bicanaux et multicanaux, tout simplement parce que c'étaient les seules méthodes utilisables en pratique. Aujourd'hui, cependant, grâce aux progrès continus effectués en particulier dans la technologie des semi-conducteurs, l'application des techniques numériques à des problèmes résolus autrefois par des moyens analogiques devient de plus en plus courante. On peut citer par exemple l'emploi croissant des techniques de transformation de Fourier rapide dans les mesures en bande étroite en temps réel sur un canal, qui ont été, à une époque, le domaine réservé de l'analyseur à compression de temps. De même, le filtrage numérique tend à remplacer le banc de filtres analogiques qui a formé, pendant si longtemps, la base des analyseurs en temps réel travaillant avec un pourcentage de bande constant.

## **ZUSAMMENFASSUNG**

In den letzten Jahren ist die Tendenz Echtzeitfrequenzanalysen mehr und mehr in digitaler Technik zu erstellen immer stärker geworden. Digitale Methoden wurden zeitweise zur Berechnung von Kreuzkorrelationsmessungen u.ä. in Zwei-oder Vielkanalsystemen benutzt, einfach, weil sie die einzigen, praktisch gebräuchlichen Methoden sind. Jetzt aber wird mit

---

\* Paper presented at SEECO 77 Imperial College, London

dem kontinuierlichen Fortschritt der Halbleitertechnologie der Gebrauch digitaler Technik für Probleme, die einst mit analogen Methoden gelöst wurden, immer größer. Hierdurch ist die immer stärkere Verwendung der schnellen Fourier Transformation in Einkanalechtzeit-Schmalbandmessungen, einst eine Domäne der "Time Compression"-Analysatoren, zu beobachten. Ebenso ersetzen digitale Filter die Analogfilter, welche so lange die Basis der Echtzeitanalysatoren mit konstanter relativer Bandbreite waren.

### **A brief history**

The real-time frequency analyzer, as a piece of commercially available laboratory equipment, first appeared a little more than ten years ago. Initially, operation was only on a linear frequency scale, using the so-called time compression technique. This involved using a frequency transformation to speed up analysis times to those required for real-time processing. The problem of real-time analysis on a logarithmic frequency scale was solved a little later, with the introduction of the parallel filter analyzer, usually operating in  $1/3$  octaves. The distinctive feature of both systems was that the method used to convert the data under analysis from the time domain to the frequency domain was analog in nature, being a heterodyne analyzer in the case of the time compression analyzer, and a bank of parallel analog filters and detectors, in the case of the parallel analyzer.

Simultaneously with the beginnings of real-time frequency analysis, interest began to grow in the digital conversion of data between the time and frequency domains. The Fast Fourier Transform algorithm (FFT), had at last given an efficient means of evaluating a Fourier Transform digitally, and digital filtering processes were gaining acceptance. However, the building of a dedicated hardwired FFT or digital filter processor, such that the speeds required for real-time processing could be achieved, could not be justified as a commercial venture on economic grounds. Hence, their use was largely limited to computation systems where they could be implemented in software form.

The above situation was changed by a series of developments in the component industry. Particularly, the development of large-scale integration, (LSI), in the semiconductor industry made the all-digital laboratory real-time frequency analyzer an economic reality which could compete with analog, (i.e., parallel filters), or hybrid, (i.e., time compression analyzers, which by now were becoming increasingly digitally based), on the same ground. As a result of this, over the past two years or so, several systems using FFT as their operating principle have been introduced. More recently the introduction of a system using digital filtering has been seen. The future of real-time frequency analysis would certainly seem to be firmly entrenched in the digital field.

### FFT or Digital Filtering

How this question is answered depends largely on the type of measurement which is being carried out. In some cases, for example, the analysis of signals from rotating machines, a linear frequency scale is required, since it is on this scale that the harmonic patterns between components can most easily be seen. On the other hand, for other cases, such as structural testing, or acoustical investigations, a logarithmic frequency is best chosen, because in the first example, structural responses almost always behave in a constant Q manner, while in the second example, the human ear responds in a very similar manner to a real-time 1/3 octave analyzer.

In the following sections, it will be shown that while FFT is ideally suited to measurements on a linear frequency scale, digital filtering becomes preferable for measurements on a logarithmic frequency scale.

### Fast Fourier Transform

The Fourier Transform integral pair provide a means of transforming a time function  $f(t)$  into its complex function  $F(\omega)$ , and back again. It is written as follows:

$$F(\omega) = \frac{1}{2\pi} \int_{-\infty}^{\infty} f(t) \exp(-j\omega t) dt$$

$$f(t) = \int_{-\infty}^{\infty} F(\omega) \exp(j\omega t) d\omega$$

Discrete equivalents of these equations may be written as follows:

$$F(k) = \frac{1}{N} \sum_{n=0}^{N-1} f(n) \exp\left(-j \frac{2\pi nk}{N}\right)$$

$$f(n) = \sum_{k=0}^{N-1} F(k) \exp\left(j \frac{2\pi nk}{N}\right)$$

These equations form the Discrete Fourier Transform, or DFT.

The DFT lends itself to digital computation procedures. However, its direct evaluation is a lengthy procedure, requiring some  $N^2$  complex mul-

tuplications to generate an  $N$  point transform. FFT, on the other hand, is a more efficient means of evaluating the DFT, requiring approximately  $N \log_2 N$  complex multiplications to perform the same operation.

In its most general form, when the FFT algorithm is applied to a block of data consisting of  $N$  complex time domain points,  $N$  complex frequency domain points will be produced, where  $N$  is usually a power of 2. If a sampling frequency of  $f_s$  is used to gather the time domain points, then the frequency domain points will be evenly distributed from DC to  $f_s$ .

Although it is normal only to talk about the points from DC to  $f_s$ , DFT, and hence FFT like it, produce a spectrum which is periodic about the sampling frequency  $f_s$ , i.e., it is repeated between  $f_s$  and  $2f_s$ ,  $2f_s$  and  $3f_s$ ,  $-f_s$  and DC, etc. From this, it is not difficult to see that the points from  $-f_s/2$  to DC will be the same as those from  $f_s/2$  to  $f_s$ , meaning that the points from  $f_s/2$  to  $f_s$  in the transformed data must represent the negative frequency components. Hence, it can be said that the FFT process generates the spectrum between  $\pm f_s/2$ .

By accepting the restriction that the time domain points can only be real-valued, a further increase in efficiency can be obtained. Such a function gives conjugate even spectrum, meaning that the negative frequency components can always be generated from the positive ones, and vice versa. Hence, only one half of the spectrum is needed to characterise it completely. This enables  $N$  real-valued time domain points to be transformed as  $N/2$  complex points, a manipulation being performed to obtain the original time function's spectrum from DC to  $f_s/2$ .

The bandwidth and selectivity of each frequency domain point is governed by the window function. The FFT algorithm automatically applies a rectangular window to the time domain data, which can have a highly detrimental effect on selectivity. Hence, prior to transformation, it is normal to multiply the time domain data by another window function to give a better selectivity, although this is normally at the expense of 3 dB bandwidth. The frequency interval between each point, or resolution, is automatically set by the transformation process as being  $f_s/N$ .

Each transformed frequency domain point will have the form  $F(i) = a_i + jb_i$ . For real-valued time functions, the negative frequency components will be of the form  $F(-i) = a_i - jb_i$ . The spectrum can be left in complex form for further processing, or converted to the RMS spectrum.

## Digital Filtering

Although FFT is ideally suited to producing information on a linear frequency scale, it cannot be adapted to a logarithmic frequency scale. Further, attempts to convert information produced by FFT to a logarithmic frequency scale have only met with a very limited degree of success. Hence, in this field of measurement, it is necessary to turn to an alternative technique, namely, digital filtering.

There are three basic classes of digital filter, these being recursive, non-recursive, and convolution. Here, only the recursive type will be discussed.

The block diagram of a generalised 2-pole recursive digital filter is given in Fig.1 of the previous article. Its transfer function can be expressed, using z transform notation, as follows:

$$H(z) = \frac{A_0 + A_1 z^{-1} + A_2 z^{-2}}{1 - B_1 z^{-1} - B_2 z^{-2}}$$

The filter response is determined by the multiplier coefficients  $A_0$ ,  $A_1$ ,  $A_2$ ,  $B_1$ , and  $B_2$ .  $B_1$  and  $B_2$  govern the poles of the filter, and  $A_0$ ,  $A_1$ , and  $A_2$  the zeroes. These multiplier coefficients determine the relative properties of the filter, i.e., its shape, its relative bandwidth, and whether it is highpass, lowpass, bandpass, or bandstop. The frequency range in which the filter operates is determined by  $z^{-1}$ , which in turn is determined by the sampling frequency. Hence, the sampling frequency is effectively a tuning frequency and, e.g., doubling the sampling frequency will mean that the filter keeps the same relative characteristics, but operates one octave higher.

A complete filter may consist of several of the basic 2-pole units shown, (note that noise considerations usually make it preferable to build a multipole filter by cascading several 2-pole units), and it operates on a sample to sample basis, i.e. operation is continuous rather than blockwise, (as is found with FFT). Since a change of a factor of 2 in the sampling frequency gives a corresponding octave change in the frequency range of operation of the filter, it is usually convenient to operate the filter on an octave to octave basis. Changes within an octave are then produced by changing the filter multiplier coefficients: for ex-



ample, in a  $1/3$  octave system, three different sets of multiplier coefficients would be used, with each set producing one of the third octaves within an octave. Changes from octave to octave are produced by successively halving the sampling frequency.

The mode of operation of the filter described above automatically produces data on a logarithmic frequency scale. It hence becomes preferable to FFT when a logarithmic frequency scale is required. A further advantage of such a digital filter is that since it is operating on a continuous signal, windowing effects are absent. Hence, the relative filter characteristics are a function of the filter multiplier coefficients only. This enables digital filtering to be used to produce highly standardized filter shapes such as octave and  $1/3$  octave.

### **Analog or Digital?**

In the previous sections, two entirely digital methods of frequency analysis, i.e., FFT and digital filtering, were described. FFT is the digital equivalent of the hybrid time compression system, while a digital filter operating in real-time can be used to replace the analog parallel filter bank. In this section the digital systems will be compared with their analog or hybrid equivalents.

The two digital systems have several common advantages when compared with their analog or hybrid equivalents. The first of these is that the digital system is inherently more stable. By this, it is meant that the systems are less susceptible to changes in environment. Typically, the digital system will have its accuracy specified as a single figure over its entire environmental operating range. The equivalent analog or hybrid system, on the other hand, will require that its accuracy is only specified at a single temperature with a temperature coefficient, or is specified within wider limits to take account of variations in system sensitivity with temperature. Another way in which this stability manifests itself is in the effects of the aging of components. With the digital system, the effects of aging, (except, perhaps, within the ADC), are almost totally insignificant.

The second common advantage of the two digital systems is an improved linearity. In both systems, the only significant source of amplitude non-linearities is within the ADC. Likewise, their frequency axes are set by the sampling frequency, which in turn is referenced to a crystal controlled oscillator. Hence, the sampling frequency can be controlled to a high degree of accuracy, to give an exceptional frequency linearity.

The third common advantage of the two digital systems is increased flexibility. Although this is not so apparent when comparing FFT with time compression, it becomes very much more so when digital filtering is compared with analog filtering. This is because with a digital filter, the same hardware can be made to represent a seemingly infinite number of different filter shapes, simply by programming in different filter coefficients. Hence, the same hardware could be used to generate octave, 1/3 octave, 1/6 octave, 1/12 octave, 1/24 octave, etc..

So far, possibly the greatest advantage of the purely digital real-time analysis system has been ignored. This is that when the frequency analysis process is operated in real-time, then real-time digital detection also becomes possible. (Note that in an FFT system, real-time processing requires that a new spectrum of the input signal is generated at least every  $1/B$  seconds, where  $B$  Hz is the bandwidth of each channel. In a digital filtering system, the digital filter should process and output sufficient samples in each channel such that the sampling theorem is obeyed in each channel.) It is a feature of digital detection that it is a purely mathematical process, with no inertia, and none of the physical limitations found in analog detectors. Hence crest factor limitations are reduced to a question of dynamic range. As long as the analysis system has sufficient dynamic range to respond to the signal being input, then the RMS level of the signal can be accurately detected as long as the signal is stationary. When the digital detection process operates in real-time as well, then the types of signal which can be detected are extended. Since real-time digital detection allows for no loss of data then the system can respond predictably and accurately to all types of signal input, whether they be stationary or non-stationary, continuous or impulsive. In short, within the limits of its frequency and dynamic ranges, a digital detector operating in real-time forms an ideal RMS detector.

Given digital detection, it is the natural thing to do to follow it up with digital averaging. This allows linear averaging to be carried out, a process difficult to achieve by analog means. Linear averaging allows an equally weighted average over a fixed time period, i.e., all events happening within the averaging period have an equal influence on the final result formed. This makes linear averaging an ideal process to use whenever it is important to ensure that all data entered is equally weighted, e.g., in spatial averaging, or averaging over one or more cycles of a machine. Where a running average is required, e.g., in monitoring processes, exponential averaging, which is a digital equivalent of analog RC averaging, can be built in using a fairly simple algorithm.

In a fully digital system, the detector and averager work together, with the averager accumulating the MS level. Since a change of averaging time only requires a change in a constant used in the averaging equation, it is possible to provide a wide range of averaging times. Conversion to RMS values takes place on output from the averager.

Given the above, somewhat formidable list of advantages of the purely digital system, are there any ways in which the analog or hybrid system technology can outperform it? The answer to this is a qualified yes, when talking about the higher frequency regions. In a digital system complexity increases with increasing frequency, while in the equivalent analog system, the complexity of analog filter is decreasing, (note that the opposite is true at low frequencies). Hence once the economic limits of digital real-time processing have been reached, it remains necessary to return to analog technique. However, it is arguable as to whether real-time processing is necessary at higher frequencies. In sound measurements, real-time processing is desirable throughout the audio frequency range, since acoustic noise can be notoriously non-stationary by nature. In the mechanical world, however, the signal under analysis often exhibits a high degree of stationarity, and often the requirement is for fast analysis. Here, a limit of real-time processing of, say, 2 kHz or 5 kHz would be perfectly adequate, unless the signal is non-stationary. Hence, the conclusion is that although for most acoustical measurements, real-time processing is desirable up to 20 kHz, for mechanical measurements, a rather lower limit can be accepted.

### **Conclusions**

The object of this paper was to compare analog and digital systems. So far, the comparison has been to some extent academic. However, in conclusion, it might be useful to briefly compare the systems commercially available today, analog filtering against digital filtering, and time compression against FFT. In the case of the analog filter against the digital filter real-time analyzer, the digital filter version clearly holds all the advantages, unless operation to very high frequencies is required. The only field which would seem to remain open to analog technology is the simple low cost system. However, as logic prices reduce further, it can only be a matter of time before this field is also encroached by digital technology.

In the comparison of time compression and single channel FFT systems, the division is not so clear-cut. FFT gives advantages in terms of dynamic range and linearity. However, at the present time, price for price, time compression can give a higher real-time limit. Hence, the

choice is a difficult one. Once again, though, it can be forecasted that as logic prices continue to drop, FFT will more and more dominate the single channel constant bandwidth real-time analyzer market. As a final comment, it should be said that where FFT really comes into its own is in a two or more channel analysis system.

## News from the Factory

### Electroacoustic Telephone Transmission Measuring Systems Types 3354 and 3355

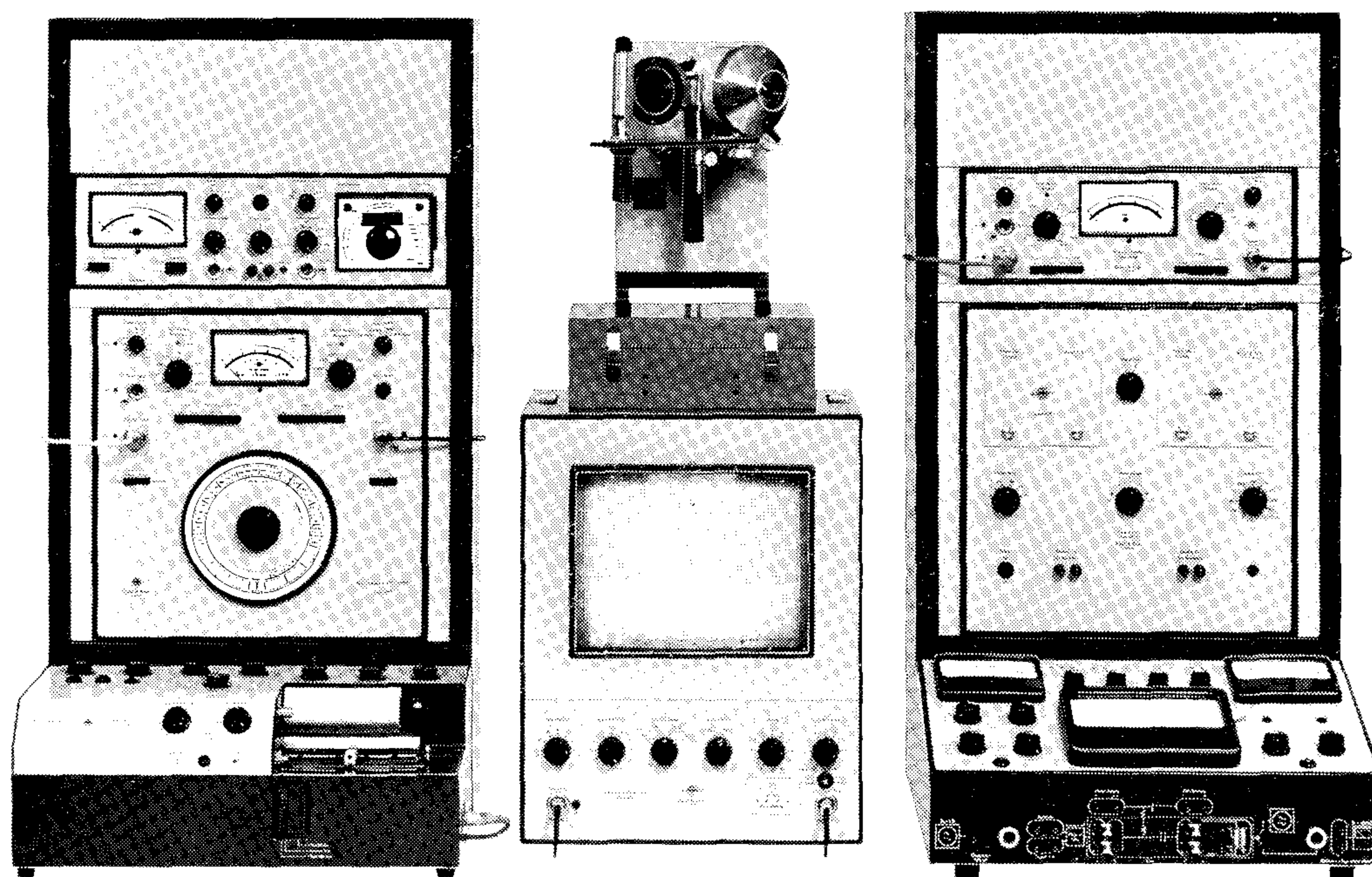

The Brüel & Kjær Electroacoustic Telephone Transmission Measuring Systems Types 3352 and 3353, which are used in most of the post and telegraph and telephone manufacturing establishments have recently had a face lift. In the new systems, Types 3354 and 3355, Sine Generator Type 1022 has been replaced by the new Type 1023 which permits electronic sweep synchronization between the generator, spectrometer, recorder and response tracer. The Level Recorder Type 2305 has been replaced by the newer type 2307.

A precise and stable stimulus is applied to the telephone instrument in the form of a continuous fast reciprocating sweep or a slow one-way

sweep, and the output from the telephone is fed to a group of instruments for display, measurement, analysis and recording. The sweep range conforms to multiplex standards, sweeping from 300 Hz to 3300 Hz back to 300 Hz once per second. A front-panel switch converts this to the standard 200 Hz to 4000 Hz to 200 Hz per second. Connections to the subset are through balanced 600 and 900  $\Omega$  transformers, centre-tapped and with optional earthing. The Test Head uses REF or AEN modal positions and meets the requirements of European and American conditioning practices. Four artificial ear couplers are supplied, each easily interchangeable: these include the IEC audiometric ear and the 6 cc ANSI (ASA) coupler.

The systems perform according to OREM A and OREM B the acoustic analysis of complete telephone sets and transmission systems. They can measure objective reference equivalent, frequency response and distortion for sending, receiving and sidetone damping conditions.

### **Triaxial Accelerometer Type 4321**

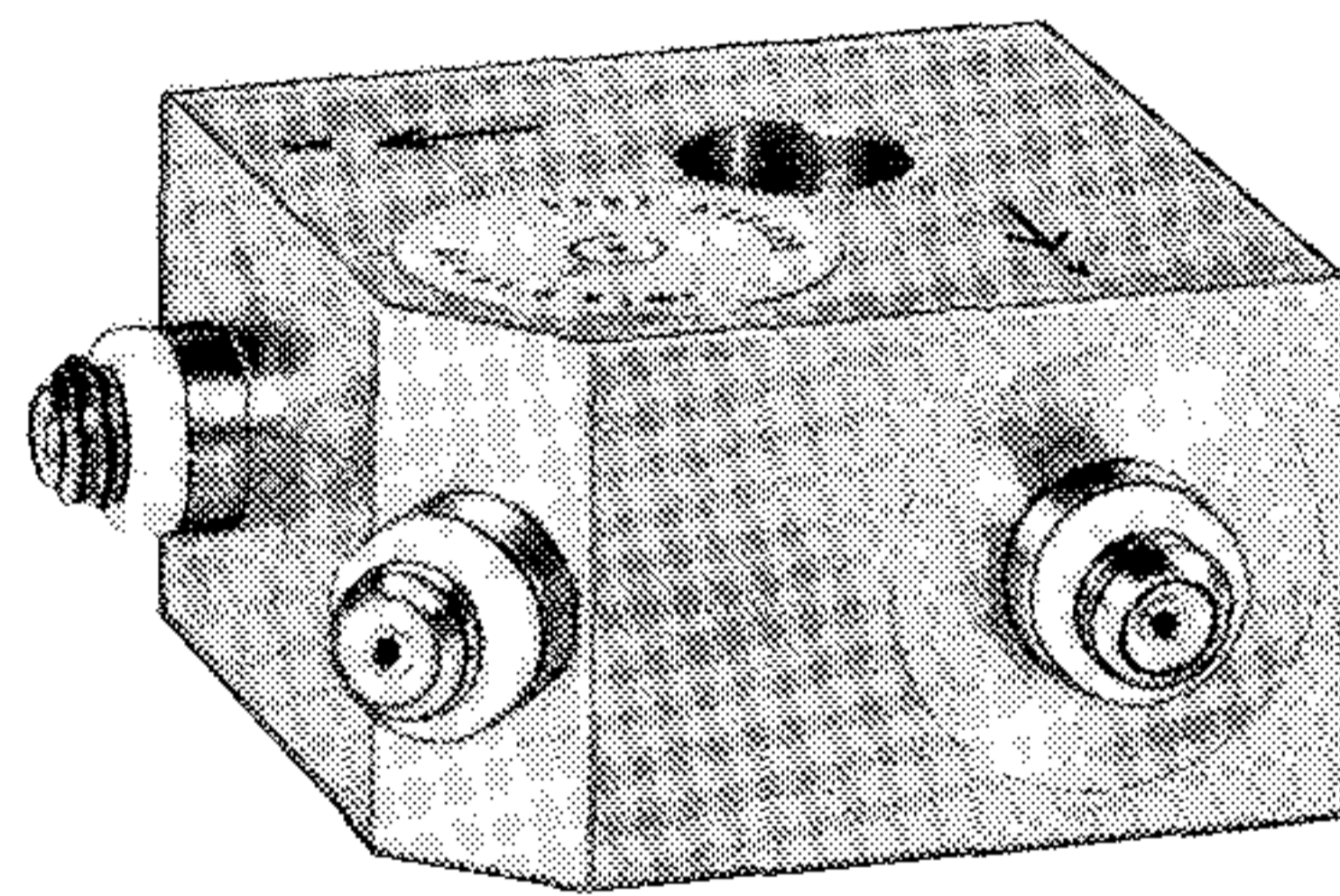

This transducer consists of three individual accelerometer elements with their principal axes mounted perpendicular to each other, for detection of vibration in three mutually perpendicular directions. Each element is a Uni-Gain<sup>®</sup> type, so that their sensitivities are all 1 pC/ms<sup>-2</sup> within a 2% tolerance, a feature which particularly simplifies system calibration and read out of levels when the accelerometer is used with fixed-gain charge preamplifiers.

The three accelerometers contained in 4321 are of the new "Delta Shear" type and have therefore a particularly low sensitivity to temperature transients and other environmental influences. For ease of mounting, the 4321 can either be fixed by means of a 4 mm screw passing through the body or by means of 10-32 UNF stud into the base of the accelerometer.

## High Sensitivity General Purpose Accelerometer Type 4370

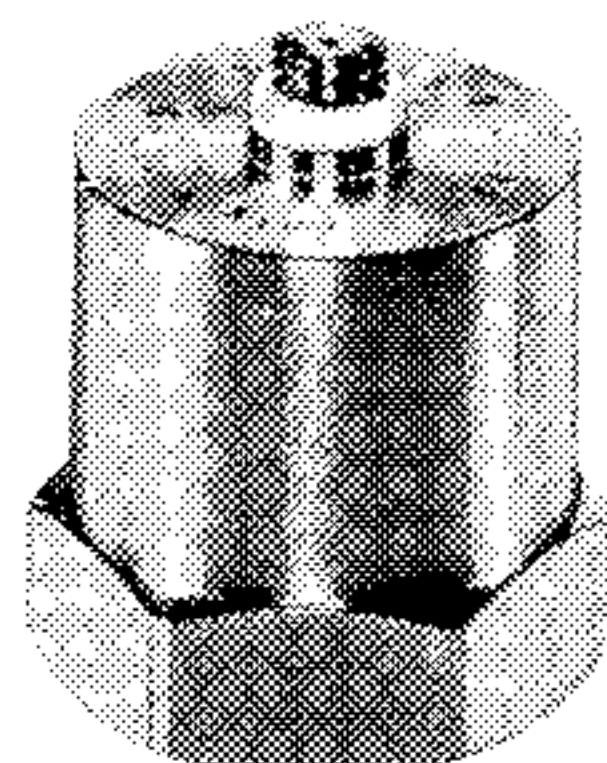

The General Purpose Accelerometer Type 4370 replaces Type 4338 and is supplied as the standard vibration pick-up with the Vibration Meter Type 2510 and Vibration Severity Meter Type 2511. On account of the new Delta Shear<sup>®</sup> design used in this accelerometer, it gives a significant improvement over its predecessor in exhibiting reduced sensitivity to base strains and temperature transients. It is a Uni-Gain<sup>®</sup> accelerometer with a sensitivity of  $10 \text{ pC/ms}^{-2} \pm 2\%$ . It is optimized to have good all-round specifications making it suitable for applications in industry, laboratory and in education.

## Audiometer Type 1800

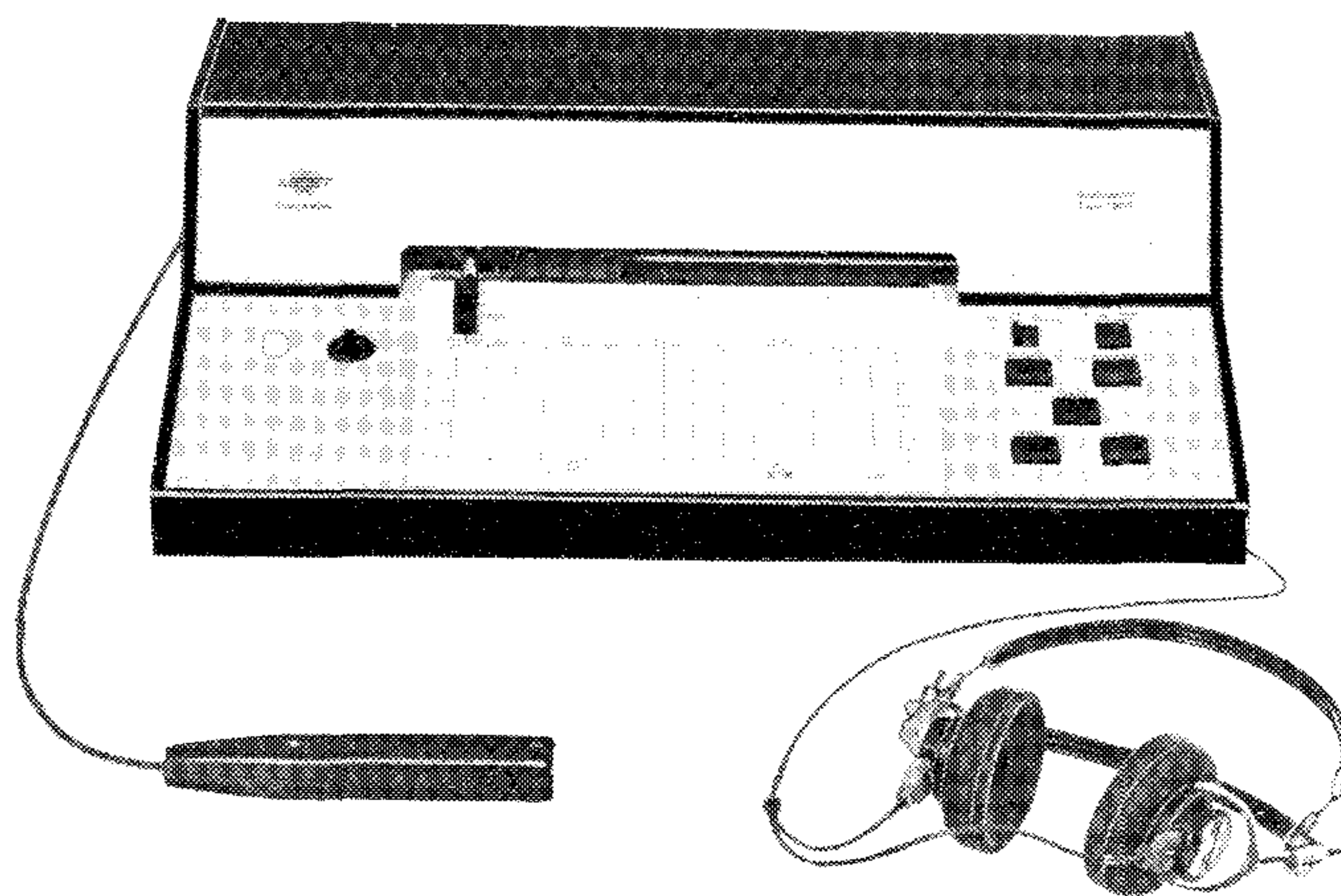

Hearing loss caused in industry due to high noise levels has led to the introduction of statutory audiometry in several countries. The Audiometer Type 1800 which complies with IEC R 178 and ANSI S 3.6-1969 is well suited for use in hearing conservation programmes as well as in audiometric research work. It is a recording audiometer for Bekesy-type audiometry, providing a fixed frequency, pure tone signal at 7 different frequencies and automatic recording of the patient's response.

The audiometer is basically an X—Y recorder with a built-in test signal generator. The X axis represents the test frequency while the deflection on the Y axis which is controlled by means of a handswitch operated by the patient, represents the hearing threshold of the patient. The handswitch operates an automatic attenuator, which controls the level of the signal supplied to the earphones worn by the patient. The button of the handswitch when pressed down decreases the level and is released by the patient when he no longer hears the signal. The patient hereby tracks his own threshold level, eliminating potential errors due to operator fatigue and variation.

The sequence of frequencies 500, 1000, 2000, 3000, 4000, 6000 and 8000 Hz generated by the oscillator is first presented to the left ear and then to the right, each tone for 30 seconds, the shift between the frequencies being noiseless. After both ears are tested, a 1 kHz tone is presented to the right ear to provide a useful indication of test reliability.

Two signal modes are selectable, "Pulse" or "Continuous". In the "Pulse" mode the test signal is modulated giving a signal easily recognizable by the patient. In the "Continuous" mode no modulation is applied giving a signal suitable for use when calibrating the audiometer.

The earphones supplied with the instrument are stable and have a good frequency response. A noise excluding headset is available for use in environments with higher ambient noise levels.



## PREVIOUSLY ISSUED NUMBERS OF BRÜEL & KJÆR TECHNICAL REVIEW

*(Continued from cover page 2)*

- 1-1974 Measurements of averaging times of Level Recorders Types 2305 and 2307.  
A simple Equipment for direct Measurement of Reverberation Time using Level Recorder Type 2305.  
Influence of Sunbeams striking the Diaphragms of Measuring Microphones.
- 4-1973 Laboratory tests of the Dynamic Performance of a Turbocharger Rotor-Bearing System.  
Measurements on the Resonance Frequencies of a Turbocharger Rotor.
- 3-1973 Sources of Error in Noise Dose Measurements.  
Infrasonic Measurements.  
Determination of Resonance Frequencies of Blades and Disc of a Compressor Impeller.
- 2-1973 High Speed Narrow Band Analysis using the Digital Event Recorder Type 7502.  
Calibration Problems in Bone Vibration with reference to IEC R 373 and ANSI S3. 13-1972.  
An Investigation of the Near Field Screen Efficiency for Noise Attenuation.

### SPECIAL TECHNICAL LITERATURE

As shown on the back cover page Brüel & Kjær publish a variety of technical literature which can be obtained free of charge.

The following literature is presently available:

Mechanical Vibration and Shock Measurements

(English, German, Russian)

Acoustic Noise Measurements (English, Russian), 2. edition

Architectural Acoustics (English)

Standards, formulae and charts (English)

Catalogs (several languages)

Product Data Sheets (English, German, French, Russian)

Furthermore, back copies of the Technical Review can be supplied as shown in the list above. Older issues may be obtained provided they are still in stock.

